

Technical information

for range hood

2024



1 Note on content

Please note

All information is provided without any guarantees. In this document, simple sketches are used to illustrate operating modes, types of construction and planning proposals. Please note that the sketches are not drawn to scale. For accurate illustrations of our products, please use the planning aid for kitchen appliances.

Text, diagrams and data correspond to the technical standard of the appliances at the time this tech info went to press. The right to make technical modifications for the purpose of the further development of the appliances is reserved.

Symbols used

- ▶ Indicates step-by-step instructions.
- Indicates a list.



Denotes useful tips for the user.



Extraction



Replacement air



Recirculation



Exhaust or replacement air unit on the ceiling



Exhaust or replacement air unit on the wall

Glossary

Cooking vapours	Water vapour containing grease and moisture which is produced when cooking.
Extraction	Kitchen air which is blown out of the building envelope by the appliance.
Recirculation	Kitchen air which is recirculated in a system, i.e. in circulation.
Outgoing air	Air which is extracted by the comfort ventilation system.
Replacement air	Air in the system after air treatment until it enters the supplied room.

Supplementary documents

In this tech info, occasional reference is made to supplementary documents which can be obtained from our Head Office in Zug on telephone number + 41 58 767 67 67 or on the Internet from www.vzug.com.

Useful links

- www.vzug.com
- www.vzug.com/b2b
- www.lifestyle.vzug.ch



Table of contents

1	Note on content	2
2	Introduction and guarantee information	4
2.1	Guarantee.....	4
2.2	What can I expect from a range hood?.....	4
2.3	The most important functions of a range hood.....	4
3	Types of construction	5
3.1	Island hoods.....	5
3.2	Wall hoods.....	5
3.3	Built-in range hoods.....	6
3.4	Hood fans.....	7
3.5	Hob hood.....	7
3.6	Hob with integrated range hood.....	8
3.7	Downdraft hoods.....	8
3.8	Cooking without a range hood.....	9
4	Operating modes – extraction, recirculation or combined with comfort ventilation	10
4.1	Extraction.....	10
4.2	Recirculation.....	11
4.3	The advantages and disadvantages of the two different operating systems.....	11
5	Function of a range hood	12
5.1	Metal grease filters.....	12
5.2	Activated charcoal filters.....	12
5.3	Edge extraction.....	13
6	General installation notes	14
6.1	Plan well to ensure efficient kitchen ventilation.....	14
6.2	Installation height for the range hood and hob.....	14
6.3	Range hood, hob overlap.....	15
6.4	Hob type.....	16
6.5	Installation type.....	16
6.6	Installation notes.....	16
7	Planning, calculation and use of recirculation hoods	18
7.1	Foreword.....	18
7.2	Range hoods with standard activated charcoal packages.....	18
7.3	Range hoods with long-life activated charcoal filters.....	18
7.4	Range hoods with long-life-Plus activated charcoal filters.....	19
7.5	Built-in hoods with air recycling cassettes.....	19
7.6	Wall hoods in recirculation mode.....	20
7.7	Air outlet in the kitchen cabinets.....	20
8	Planning, calculation and use of extraction hoods	21
8.1	Foreword.....	21
8.2	Firing systems dependent on ambient air.....	21
8.3	Controlled replacement air.....	22
8.4	Exhaust air layout.....	24
8.5	Calculation and layout of extraction hoods.....	29
9	Care and maintenance	32
9.1	Handling filters.....	32
10	Troubleshooting	33
10.1	What to do if.....	33



2 Introduction and guarantee information

2.1 Guarantee

V-ZUG guarantees the highest quality and functionality of its appliances, provided that the ventilation technology is installed on-site by an expert. Consult a ventilation specialist.

2.2 What can I expect from a range hood?

People should feel comfortable and happy to spend time in the kitchen, but for that you need sophisticated technology. V-ZUG not only helps to increase the level of hygiene in your kitchen, but also your sense of well-being.

This planning document should help you to find the best range hood for your needs.

2.3 The most important functions of a range hood

- Capturing cooking vapours
- Separating grease particles
- Reducing unpleasant odours

3 Types of construction

3.1 Island hoods

This type of hood is used in kitchens with an island hob and is mounted on the ceiling. The exhaust air conduit can be fed through the ceiling or through an exhaust duct at the side.



3.2 Wall hoods

This type of hood is used when the hob is installed next to the wall. The exhaust air conduit can be fed through the ceiling or through an exhaust duct at the side.

A distinction is made between horizontal wall hoods and sloping hoods. Sloping hoods have the advantage of offering more head-room.



3.3 Built-in range hoods

With a built-in range hood, optimum use is made of the space available in a kitchen. Installation in a wall unit can be planned in conjunction with a spice rack. The exhaust air conduit can be fed through the ceiling or to the side.

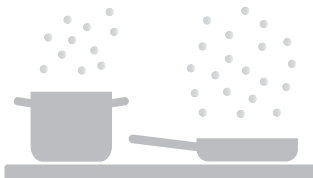

Flat panel hood in wall unit with spice rack

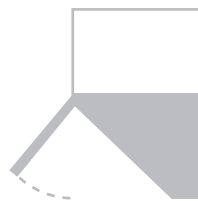

Pull-out hood in wall unit



Freely suspended fan in wall unit



All built-in appliances can be operated with an integrated activated charcoal filter. For air flow reasons, we recommend using the air recycling cassette for hoods with an activated charcoal filter under 1 kg.

3.4 Hood fans

This range hood combines the performance of the pull-out range hood with the convenience of the integrated range hood. It can disappear into a wall unit or can sit above the hob in cladding customized to match your kitchen. This makes the integrated range hood the ideal solution for people who prefer their range hood not to be on display, and it offers practically unlimited planning and design freedom for your kitchen. The sleek housing leaves storage space for recipe books, herbs and spices. Integrated range hoods are quick to install and can be used immediately.

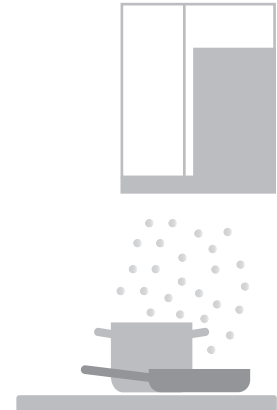

3.5 Hob hood

The hob hood is built into the kitchen worktop and extracts cooking vapours directly from the hob downwards. Cooking vapours typically rise at a rate of max. 1 metre per second. The hob hood from V-ZUG produces a powerful flow of air and draws the vapours downwards and away at a rate of approx. 7 metres per second. This type of extraction system leaves the space above the hob free and thus provides added flexibility for kitchen planning purposes.



The hob hood provides many new options when planning the kitchen layout, and it can be combined with a large number of V-ZUG hobs. The hob hood can be surface or flush mounted and thanks to its compact, space-saving installation there is still enough room for drawers. The drip tray can be removed, making it practical to clean. The drip tray can hold up to 5 dl of grease and can be simply removed from the hood and cleaned in the dishwasher.



The hob hood is operated in recirculation mode using an external recirculation box with integrated activated charcoal filter (accessory available for order).

3.6 Hob with integrated range hood

One appliance – two functions. The CombiCookTop range includes induction hobs that have a range hood integrated into the glass of the hob itself, allowing cooking vapours to be extracted directly at source.

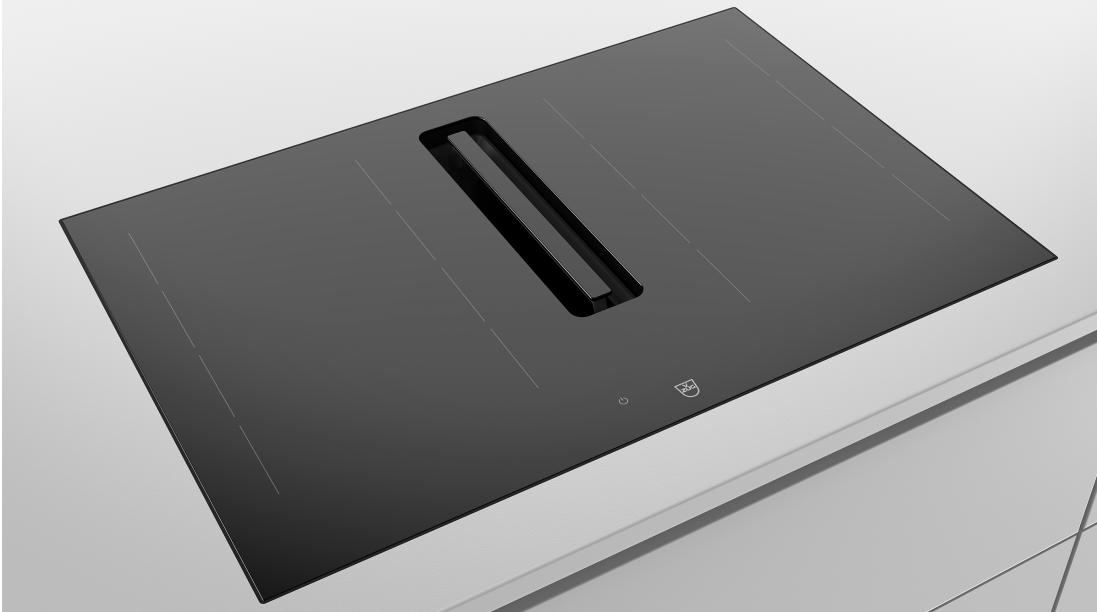

The CombiCookTop is operated in recirculation mode with the long-life-Plus activated charcoal filter (accessory available for order).

3.7 Downdraft hoods

Downdraft hoods with extendible/retractable hood body. With a downdraft hood, optimum use is made of the space available in a kitchen. The exhaust air conduit can be laid in any direction.



All downdraft hoods can be operated with an integrated activated charcoal filter.



3.8 Cooking without a range hood

Passive air renewal

Passive air renewal is based on the physical principle of convection. When the window is open, the warm air rises while fresh air flows in through windows, joints or shafts. This system is dependent on the ambient air temperature. In the summer months, continual air exchange is not possible; in the winter months, air renewal is associated with significant heat loss.

Insufficient air exchange may have undesirable consequences:

- Odours are not reduced satisfactorily.
- Cooking vapours are deposited on furniture and walls (soiling).
- The room conditions are affected for an excessively long period of time (cold air in winter, pollen in spring, etc.).
- Remote nooks are not reached by the stream of air.
- Mould formation is promoted as a result of the exterior walls cooling down.

4 Operating modes – extraction, recirculation or combined with comfort ventilation

4.1 Extraction

The extraction hood uses a fan which creates a negative pressure to draw away the cooking vapours produced during cooking, separating grease in the grease filter in the process. The moist and odour-heavy air is fed through an exhaust duct to the outside. Plans must include a wall opening or roof outlet to feed the exhaust air outside.

For an extraction hood, exhaust air always requires replacement air.

Without sufficient replacement air, an extraction hood can only achieve a small fraction of its extraction power. Therefore, plan to have units with controlled replacement air or a window contact switch. This ensures that there will always be sufficient replacement air.



Replacement air by means of window ventilation

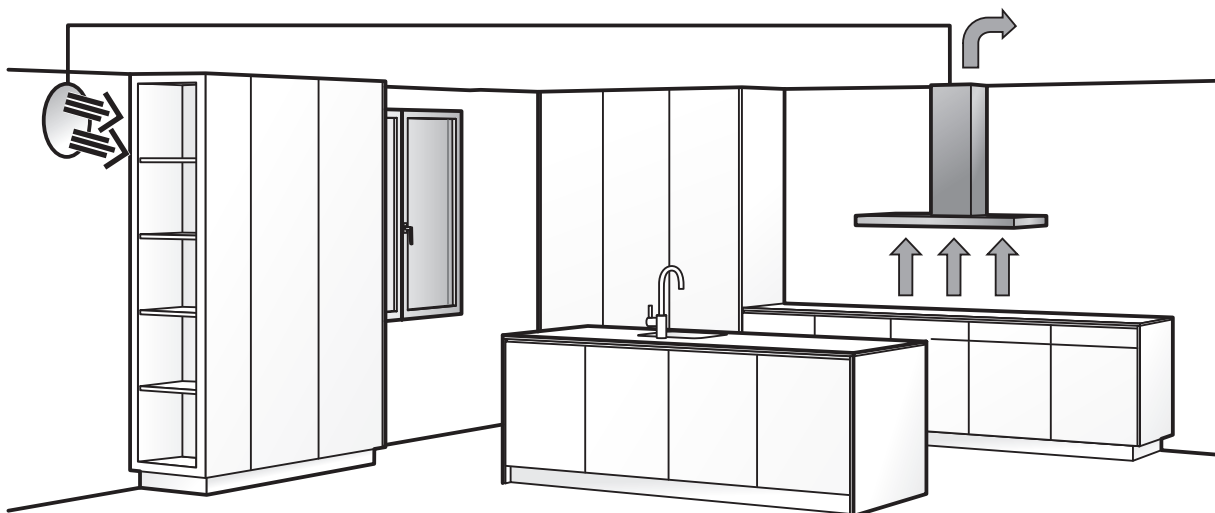

Replacement air by means of a motor flap controlled via a connection option

4.2 Recirculation

In recirculation mode, cooking vapours are drawn away by the range hood, grease is retained in the grease filter and the odours are then reduced in the activated charcoal filter. The air which has been cleaned is then fed back to the room. Depending on the cooking intensity and the quantity of activated charcoal, the activated charcoal filter may be used for several months or years before it has to be replaced by a new one.

In recirculation mode, both the heat in the ambient air and the moisture remain in the room, i.e. in circulation. The recirculation hood is often used in small, enclosed kitchens where the hob is too far away from an exterior wall. This enables costly construction work to be avoided. The recirculation hood is also suitable for new building standards to avoid having openings in the building envelope. Planning an air recycling cassette is an optimal addition to the recirculation hood. The air is blown aerodynamically along the ceiling and supports the effective suction extraction of the range hood.

Please note that recirculation appliances are less efficient at removing odours and somewhat louder in operation than extraction hoods. The majority of V-ZUG range hoods can be used as both extraction and recirculation appliances.

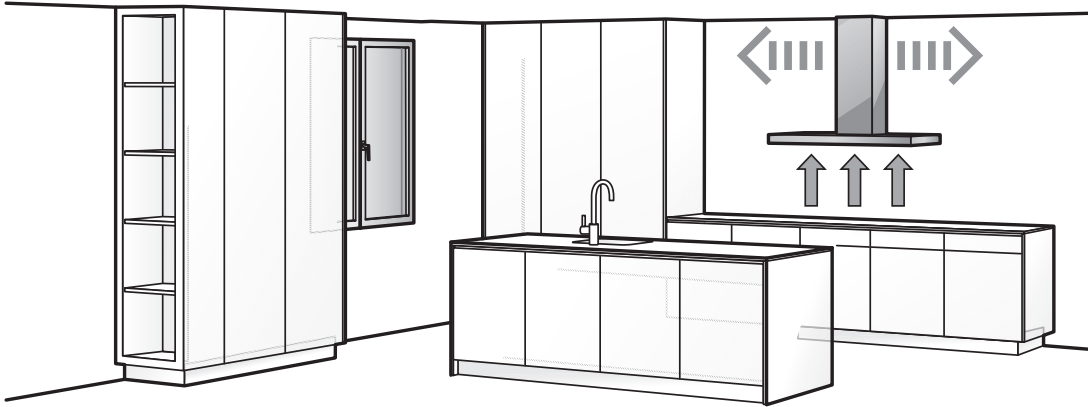

Recirculation hood

4.3 The advantages and disadvantages of the two different operating systems

	Advantages	Disadvantages
Extraction	<ul style="list-style-type: none"> • Easy and inexpensive maintenance • Very efficient • Good odour removal • Fresh air from replacement air • Moisture is vented 	<ul style="list-style-type: none"> • Heat loss • Higher costs of exhaust air installation • Thermal bridging in the exhaust air conduit
Recirculation	<ul style="list-style-type: none"> • Easy planning and installation • No heat loss 	<ul style="list-style-type: none"> • Cost of maintenance • Moisture remains in the room • Slightly reduced odour removal • Higher operating noise

Comparison of the different systems:

	Extraction	Recirculation
Exhaust air conduit	Required	Not required
Wall opening / roof outlet	Required	Not required
Replacement air	Required	Not required
Chimney / open fire	Possible with controlled replacement air	Possible
Low-energy house	Possible with controlled replacement air	Possible
Passive house (Minergie A, P)	Possible with controlled replacement air	Possible
Grill	Possible	Not recommended
Activated charcoal filters	Not required	Required
Purge ventilation after cooking	Not required	Required
Early planning	Yes	No

5 Function of a range hood

5.1 Metal grease filters

The metal grease filter works on the basis of impingement separation. Cooking vapours which are drawn away by the range hood pass through the multi-layered metal grease filter. They collide with the knitted metal fabrics arranged at a special angle and are filtered.

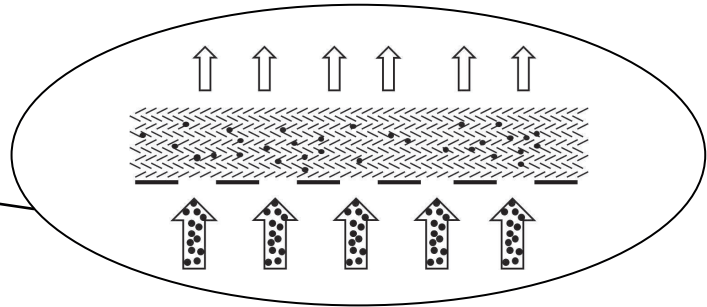

In the metal grease filter, cooking vapours flow through the filter, separating the grease in the process. Moisture and odours are fed in the exhaust air conduit to the outside.



The metal grease filters should be cleaned at least every four weeks with normal use (more frequently with intensive use) and whenever the saturation indicator alarm is triggered. If properly cared for, the grease filters should provide years of service. Cleaning may cause the metal grease filters to become slightly discoloured. However, this will not affect the functioning of the filters in any way.

If the filter is never cleaned or cleaned too late, the extraction power and grease absorption will be significantly reduced. The metal grease filter loses its effectiveness.

5.2 Activated charcoal filters

The physical principle on which the activated charcoal filter is based is adsorption¹. As part of this process, molecular bonding forces cause agglomerations of gaseous or suspended² substances to adhere to the surface of a solid. Various factors influence the effectiveness of the activated charcoal filter.



As the filter surface / odour concentration / air humidity increases, the adsorption capacity increases as well. As the air temperature/air speed increases, the adsorption capacity decreases.

¹ Adsorption

[Lat.] Adhesion and physical bonding of gases, vapours or liquids of dissolved or suspended substances to the surface of a solid, primarily porous substance. The adsorbed substance is called the adsorbate, while the adsorbing substance (e.g. activated charcoal or silica gel) is called the adsorbent.

² Suspension

[Lat.] A state in which the particles of a solid are dispersed throughout a fluid.

The activated charcoal filter is used in a recirculation hood to remove unpleasant odours from the kitchen air. It is most effective if the range hood is switched on five minutes prior to cooking. This brings the activated charcoal filter up to operating temperature and a stable flow can be established. The optimum operating temperature in the activated charcoal filter is 25–40 °C. During the summer months, higher temperatures may arise, but this reduces its ability to remove odours.

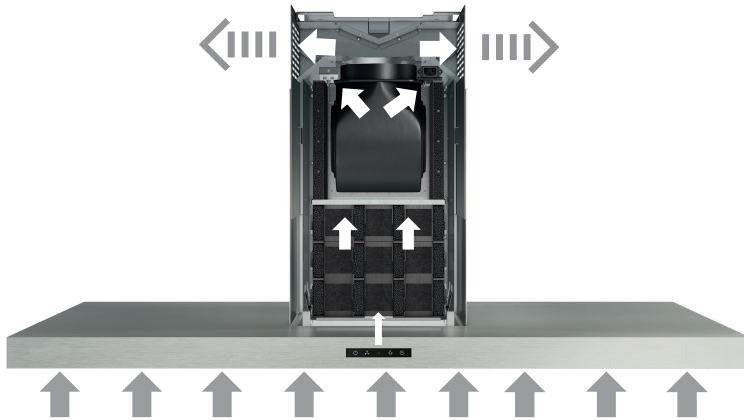

The activated charcoal filter reduces odours which are produced in the kitchen.

The basic material for activated charcoal filters consists of coconut shells and coked hard coal. The adsorption area of this material is incredibly large, as innumerable fine channels (measuring less than 1/1000 mm) run through the activated charcoal. Just 4 grammes of activated charcoal have the adsorption area the size of a football pitch measuring 75 x 110 metres.

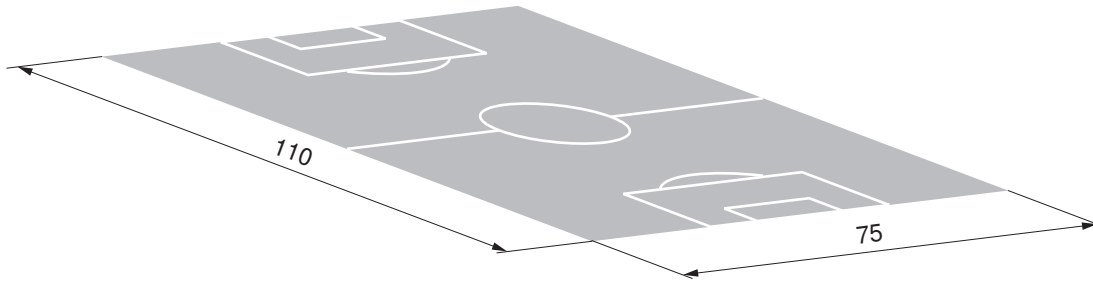

Depending on the quantity of activated charcoal, the service life of an activated charcoal filter is between three months and five years. The activated charcoal filter can be disposed of with normal household waste or at a suitable recycling point.

5.3 Edge extraction

Hoods with edge extraction are primarily suited to cooking islands, wide hobs, «cold» hobs or open-plan kitchen and living areas. Cooking vapours on the outside edge of the hob are more difficult to capture. And this is where strong edge extraction above the outside edge of the hob comes into play.

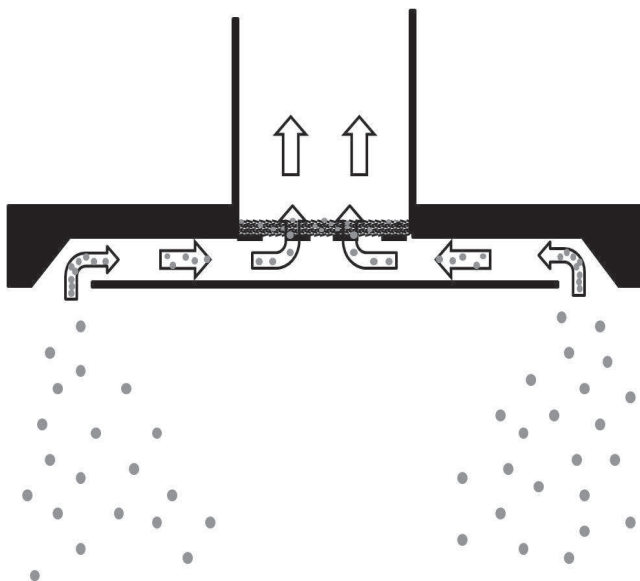

Edge extraction operating principle for an island hood

6 General installation notes

6.1 Plan well to ensure efficient kitchen ventilation

There is hardly any other room in the house which has as much technology as the kitchen. First and foremost, this technology should work without spoiling the ambience in the kitchen. Kitchen ventilation is often given too little consideration when planning, even though by doing so many mistakes could already be avoided: starting with selecting the right type of construction and operating mode tailored to the space available and individual cooking habits.

The efficiency of a suitable kitchen ventilation system depends on many factors:

- Type of construction
- Arrangement of cooking appliances
- Use of cooking appliances
- Structure of the exhaust air pipes used
- Counterpressure in the exhaust air conduit
- Force of the wind exerted on the exhaust opening
- Replacement air concept

The following information will help you to select and plan an effective kitchen ventilation system. The sections below look specifically at:

- Installation height for the range hood and hob
- Range hood, hob overlap
- Type of hob
- Installation type
- Installation notes and further information in the planning aid

6.2 Installation height for the range hood and hob

The installation height for range hoods must be adapted to the hob.

Generally, the further away the range hood is from the hob, the more difficult it is to capture the cooking vapours. If a greater distance has to be selected between the hob and range hood, e.g. for tall users or in the case of a ceiling hood, edge extraction is recommended as the cooking vapours are captured better here.

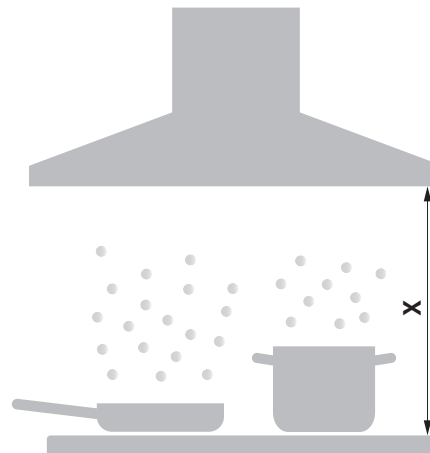

Please note the minimum installation height above a hob. The distance X depends on the type of hob (electric or gas hob). The minimum distance X from the range hood is specified in the planning aid. For different types of hobs (e.g. wood firing), please observe the regional guidelines set by fire authorities and acquaint yourself with the local installation regulations.

6.3 Range hood, hob overlap

The maximum individual freedom of movement when cooking is guaranteed if the installation height **H** of the hood is adapted to the user. The hob overlap of the hood must be adapted accordingly and be mounted symmetrically to the hob both in width and in depth.

Island and wall hoods

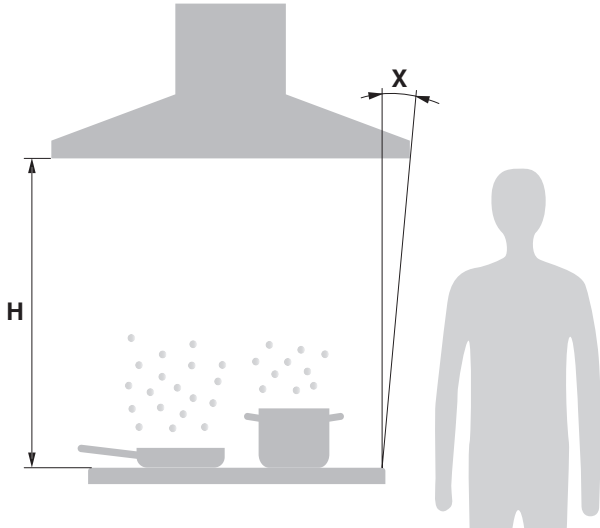

Example: Island hood

80 cm wide hob
 Height of person up to 182 cm
 Installation height **H** = 90 cm

Example: Wall hood

70 cm wide hob
 Height of person up to 165 cm
 Installation height **H** = 75 cm

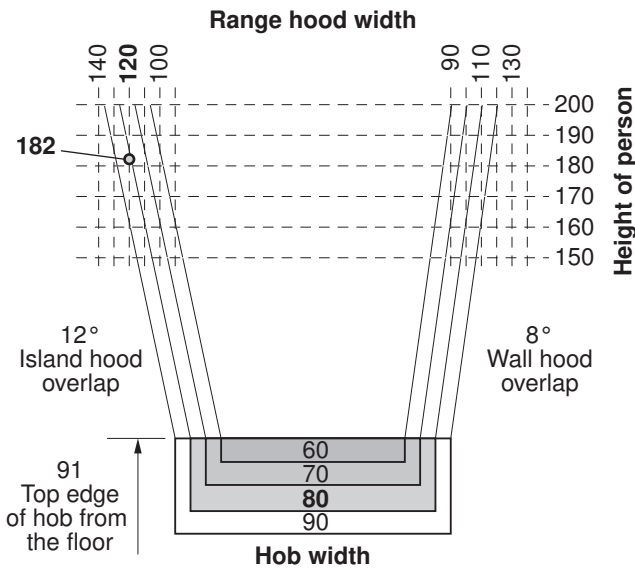

Recommendation for this example:
 120 cm wide island hood

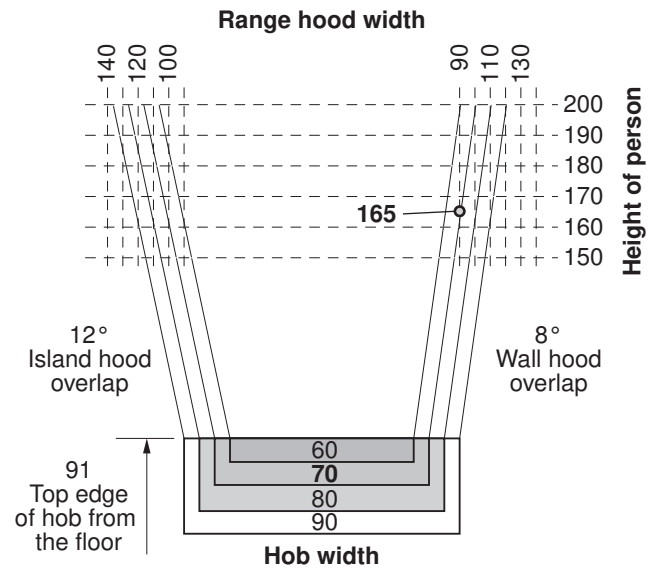

Recommendation for this example:
 90 cm wide wall hood



For an island hood, we recommend a 12° overlap **X** of the hob; for a wall hood, an 8° overlap **X**. The optimum installation height **H** is 60 cm; the maximum distance of 110 cm should not be exceeded. Some models are available in different construction widths.

Built-in and integrated range hoods

The width of the built-in hood and the integrated range hood must be selected in the same way as for the wall hood, i.e. with an overlap of 8° at the side. Built-in hoods which also have suction extraction in the deflector plate capture cooking vapours better than built-in hoods with a glass deflector plate and integrated range hoods.

6.4 Hob type

The hob is decisive for selecting the correct range hood. A distinction is made between "cold" and "hot" hobs.

In the case of "cold" hobs, the heat is generated in the saucepan, whereby the cooking vapours rise relatively slowly and have time to spread. A range hood with edge extraction is recommended for these hobs.

"Cold" hobs include induction and radiant heating element hobs as well as Teppan Yaki hobs.

In the case of "hot" hobs, a lot of heat is also produced next to the saucepans. As a result of this, the cooking vapours are trapped in the hot air and transported upwards very quickly. The cooking vapours therefore rise in a relatively straight line and quickly.

A hood with wide-area suction extraction can be installed here, but edge extraction is of course also suitable.

"Hot" hobs include gas hobs, deep fryers and grills.

6.5 Installation type

Even the best range hood is only as good as its placement in the room. It is ideally mounted on an external wall, or at least not too far from a possible outlet. In the case of a cooking island, the exhaust air duct can be fed through the ceiling to the roof, through a visible duct below the ceiling, or concealed behind a suspended ceiling.

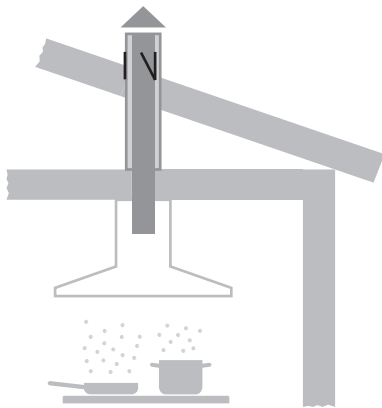

With roof outlet



With visible side exhaust duct



With concealed exhaust duct, e.g. suspended ceiling with flat channel exhaust air conduit

The non-return flap valve is installed directly behind the exhaust air cap/grille. For an island hood with roof outlet, the exhaust air piping is insulated throughout the thermal bridge area. Horizontal exhaust air conduits must be installed with at least a 1% downhill gradient towards the outside. This will enable any condensate produced to run off.

6.6 Installation notes

Installation instructions

Our range hoods are designed to be easy to install. Each appliance is supplied with specific installation instructions. The installation instructions can also be downloaded from the Internet at www.vzug.com/b2b.

Installation recommendation

- Avoid routing the exhaust duct to the side through the chimney casing.
- Planning features for non-destructive de-installation and maintenance of the appliance:
 - Do not route telescopic casing in suspended ceilings.
 - Avoid silicone joints between the telescopic casing and the appliance.
 - All plastering, plasterboarding, wall papering and painting work is to be carried out prior to installing the appliance.
- When using stone cladding, please note the width, chamfer and distances recommended in the planning aid for kitchen appliances.

Planning aid

You will find information about the full range of V-ZUG range hoods in the planning aid for kitchen appliances. All the key dimensions and technical specifications for all your planning needs are given in detail. In the planning aid you will also find detailed descriptions of the island hoods, CombiCookTops, downdraft and hob hoods, suitable flat channel systems and accessories that are available for order.

Island hood with suspended ceiling and flat channel exhaust air conduit

With a suspended ceiling, the island hood can be fixed to an installation plate (individual production). The installation plate has the advantage that the installation height to the suspended ceiling can be set precisely and is easy to implement. During the final assembly of the island hood, it can also be moved sideways and centred on the cooking island.

Materials required:

- Diverter piece for flat channel, material E130
- Flat channel 254 × 82, material E130
- Installation plate approx. 420 × 420 × 27 mm with hole for exhaust air conduit, three-ply material (individual production)
- At least six Toproc screws
- Plasterboard

Installation

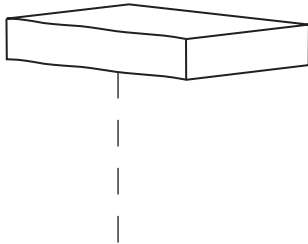

Plumb the centre of the hob and mark on the ceiling.

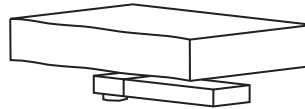

Install the diverter piece and flat channel on the ceiling.

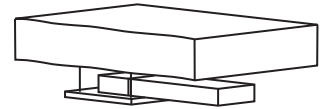

Mount the installation plate on the ceiling using at least six Toproc screws and level out.



The material of the exhaust air conduit must be E130 for this installation.

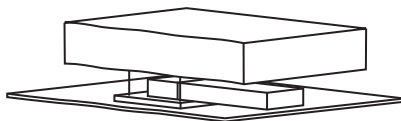

Fix the plasterboard to be flush with the installation plate. This can then be plastered or painted.

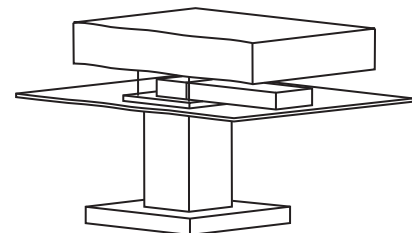

Mount the island hood on the installation plate using wood screws through the plasterboard.



There must not be a gap between the plasterboard and installation plate.

7 Planning, calculation and use of recirculation hoods

7.1 Foreword

The advantages of a recirculation hood are the minimal planning costs and the heated or cooled air remaining in the room which is not fed outside. However, as the moisture also remains in the room as a result of this, purge ventilation should be performed every time after cooking.

Once cooking is finished, the range hood should continue to run for a while at a low level. In this way, the malodorous air in the kitchen is sucked through the range hood several times and has enough time to react with the activated charcoal. The moisture is also removed from the filters as a result of this extra running time.

V-ZUG offers different types of recirculation systems. A choice can therefore be made to suit the cooking intensity and personal needs.



Recirculation hoods with standard activated charcoal and long-life filters in particular should be operated at low levels. Due to the lower air speed, the contact time in the activated charcoal filter is longer and the reduction of odours is therefore greater. The planning of a recirculation hood together with a grill and deep fryer is only recommended with restrictions.

7.2 Range hoods with standard activated charcoal packages

Depending on use, size, weight and number, the odour filter, which consists of a particular combination of activated charcoal, can have a service life of between 6 months and 3.5 years. These granules have a greater surface area and are more efficient at removing odours than the long-life filters. As the quantity of activated charcoal granules increases, the filter surface also increases. The air flows more slowly through the filter and has more time to react to the filter material. The standard activated charcoal filter cannot be regenerated and requires replacement after a given time.

7.3 Range hoods with long-life activated charcoal filters

The long-life filter from V-ZUG is an extremely economical option for all range hoods which are used in recirculation mode. Activated charcoal is applied to a porous plastic foam with a very large surface area. The activated charcoal filters the odour molecules from the air and traps them inside. The long-life filter can be regenerated and has a service life of up to 3 years. It can be cleaned every 2 to 3 months in the dishwasher or, alternatively, by hand with hot water and a mild detergent, then dried in the oven at 100 °C. During regeneration, the activated charcoal is heated and refreshed.

Cleaning

- In a dishwasher at 65 °C (intensive programme). The filter must be washed separately so that it does not become soiled by food residue.

Or:

- Immerse in 60°C water and regular detergent in the kitchen sink for an hour. Rinse well afterwards with clean water.

Reactivating

Regenerate in an oven for 60 minutes at 100° C with top/bottom heat or forced convection. Place the filter on the wire shelf.

7.4 Range hoods with long-life-Plus activated charcoal filters

V-ZUG offers recirculation hoods with long-life-Plus activated charcoal filters that provide a particularly high degree of comfort. This innovative activated charcoal filter is very effective at absorbing odours and is mechanically durable as well. It can be cleaned and re-generated every 3 to 6 months through heat generation by placing it in the oven at 200° C for 60 minutes. If properly cared for, the service life of the long-life-Plus activated charcoal filter is 3 years. The long-life-Plus activated charcoal filter is more efficient than the long-life activated charcoal filter.

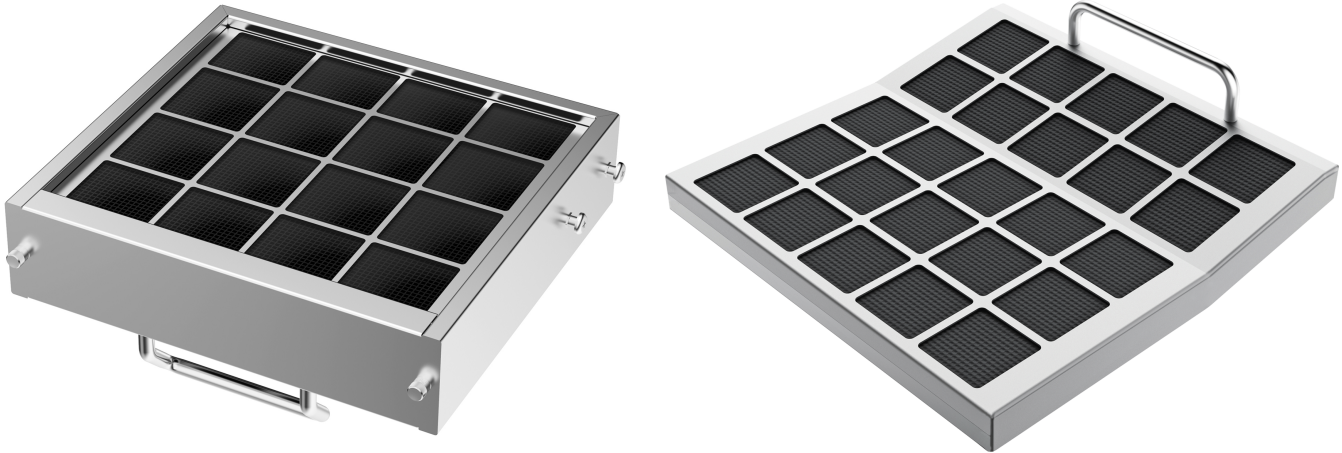

7.5 Built-in hoods with air recycling cassettes

In particular for built-in hoods for which only standard activated charcoal filters are available, we recommend dispensing with the charcoal filters in the hood and installing an air recycling cassette. This has been optimized in terms of air flow and has a larger filter surface, as well as more filter material. The activated charcoal filter is also easier to maintain than in appliances with an integrated activated charcoal filter.

The cassette is integrated in the ceiling panel. Due to this convenient position in terms of air flow, it assists with the suction extraction of the recirculation hood. The integrated large surface activated charcoal filters can be replaced without using any tools.

The installation dimensions of the hoods and further information about air recycling cassettes can be found in the planning aid.

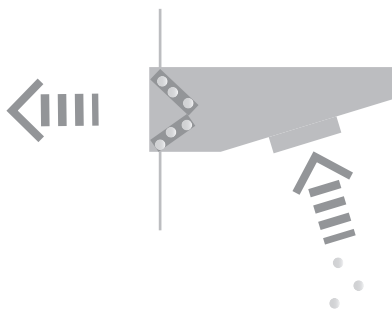

Air recycling cassette with integrated activated charcoal filter

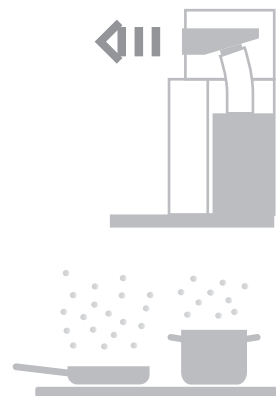

Use of the air recycling cassette with a flat panel hood

Advantages

- Warm, moist air is not blown into the rear panel of wall units
- A technically sophisticated recirculation solution
- The cassette is easy to install
- The activated charcoal filters are easy to replace
- The activated charcoal filters are protected from grease

Disadvantages

- Moisture remains in the room

7.6 Wall hoods in recirculation mode



The recirculation mode only works correctly if both side panels of the kitchen units come up to the range hood or are a minimum distance of 1 m away. As a result, the output air is not forced downwards and does not impede the suction of the hood.

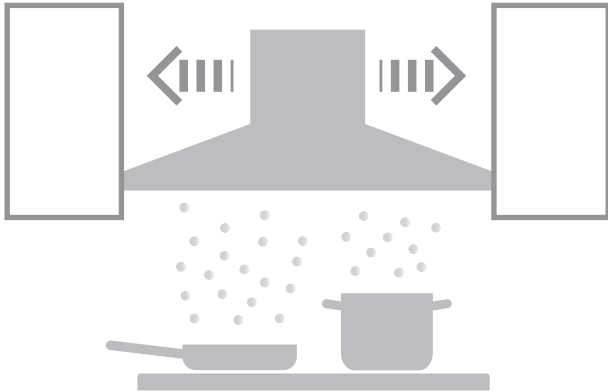

Wall hood without a gap to the side panels of the kitchen units.

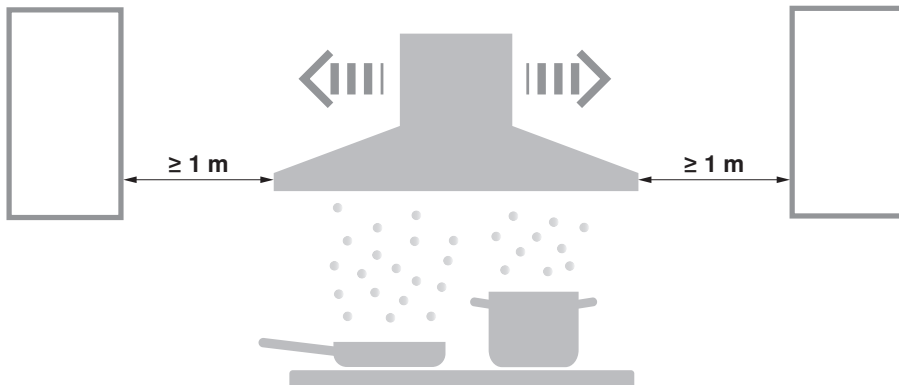

Wall hood with a minimum distance of 1 m to the side panels of the kitchen units.

7.7 Air outlet in the kitchen cabinets

In recirculation mode, outlet air must not be allowed to accumulate in the kitchen cabinets as otherwise there will be a build-up of moisture, causing the wood to swell and possibly mould to form. For recirculation mode, ensure sufficient ventilation so that moisture can escape. The kitchen cabinets should be planned for with suitable materials.

With built-in hoods, there may be undesirable air feedback and the extraction power of the hood will decrease.

Using the air outlet cassette for wall units with panels, or a recirculation set for wall units without panels which is available as an option, the outlet air can be fed back into the room in a controlled manner.





8 Planning, calculation and use of extraction hoods

8.1 Foreword

An extraction hood removes odours and moisture extremely efficiently from the kitchen. The most important thing is that plans include replacement air, especially in today's airtight building envelopes. Without sufficient replacement air, an extraction hood can only achieve a small fraction of its extraction power.

With open fires in buildings, it is also important that the negative pressure does not exceed 4 pascals. If the negative pressure is too high, combustion in an open fire can be affected such that exhaust gases enter the room.

There are two types of replacement air:

- Uncontrolled replacement air: air flows in through openings and gaps in the building envelope. However, this increases the air resistance and the extraction hood becomes significantly less efficient.
- Controlled replacement air: a replacement air unit is recommended in airtight building envelopes in particular, but also in older buildings. This can be a window which is fitted with a contact switch or an automatic replacement air unit.

Aside from the replacement air, it is also vital that the exhaust air conduit is optimally routed to the outside. The longer the exhaust air conduit and the more angles it has when laid, the greater the counterpressure and the greater the power of the hood must be.

For optimal performance of the extraction hood, it should be switched on five minutes prior to cooking so that a stable air flow can build up.

Leave the appliance running for a few minutes after cooking so as to extract all the cooking smells. For most V-ZUG range hoods, this function is integrated in the automatic after-running function.

8.2 Firing systems dependent on ambient air

In the case of extraction mode and a simultaneous fire which is dependent on a chimney, sufficient replacement air must be ensured. It is strongly recommended that an independent replacement air solution for both the range hood and the firing system be installed, with a window contact switch being preferable to any other supply air solution – only an open window provides sufficient replacement air. The negative pressure must not exceed 4 pascals in the area of the firing system. There is otherwise a risk of poisoning from the combustion gases flowing back into the room. In this regard, it is generally recommended not to use any firing system whilst the range hood is in operation.

8.3 Controlled replacement air

In the case of an extraction hood, we recommend planning a replacement air unit – particularly for extremely airtight building envelopes which comply with new building standards.

Exhaust air requires replacement air

To enable the greasy cooking vapours to be extracted as efficiently as possible, planning where the replacement air is to be located is extremely important.

To support the range hood with a replacement air unit in an optimal way, please note the following:

- Install replacement air unit directly below the ceiling to ensure air circulation to support the range hood.
- The replacement air unit is ideally planned and installed on the opposite side of the room. This prevents cross currents of air.
- The replacement air unit is ideally a minimum distance of 2 m from the extraction hood to prevent air short-circuiting.
- Replacement air can be ensured by means of an open window on the opposite side of the kitchen. Caution: If other windows or doors are open, cross currents of air may develop.
- Replacement air from near the floor will result in the cooking vapours swirling as they rise and dispersing throughout the room. The rising air supply counteracts the controlled extraction of the laden air.

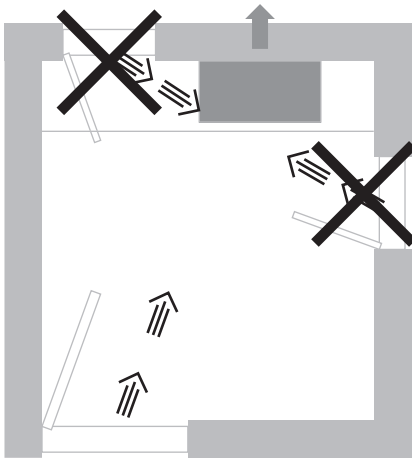

No cross currents of air which blow away the cooking vapours should be produced while the range hood is in operation.



For air flow reasons, ensure that there is a minimum distance of 2 m between the hood and the replacement air unit.

Window contact switch

A window contact switch prevents the extraction hood from being used if no window is open. A sensor registers whether the window is open and transmits a signal to a device in the hood by means of wireless technology or a cable. If you close the window, the range hood will also switch off.

The window should be at least 2 m away from the hood and positioned on the opposite side of the room.

Window contact switches available on the market – which are placed between the power socket and the mains cable of the range hood – have the disadvantage that the range hood does not work when the window is closed. And therefore the light on the hood does not work when the window is closed. Some V-ZUG extraction hoods have prepared contacts for systems where the light will also work even when the window is closed.



Replacement air units controlled by contact option

Some V-ZUG range hoods are fitted with a connection option which can be used to control an automatic replacement air unit. This means that when the range hood is switched on, a flap or a window opens and outside air flows into the kitchen. An opening in an external wall is required to install a flap.

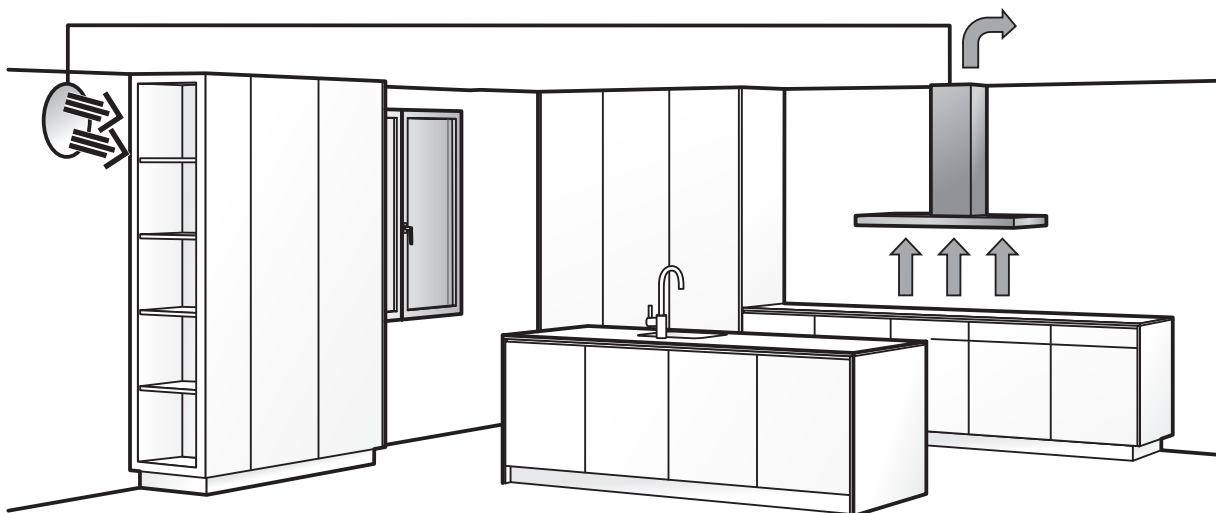



Using a replacement air unit affects the room air comfort. The colder the replacement air is, the sooner any movement in the air will become unpleasant.

We recommend planning a replacement air unit with a large inlet cross section to reduce the air speed.

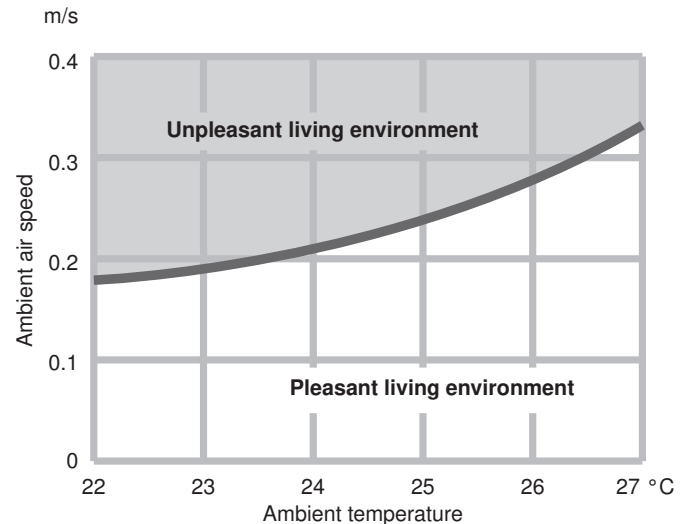

8.4 Exhaust air layout

Particular attention must be paid to planning and implementing the exhaust air conduit. The diameter of the exhaust air conduit must be adapted to the air flow rate of the hood. An exhaust air conduit which is too small can make operation of the hood difficult or even impossible. The exhaust air pipe should have a consistent nominal width which is not too narrow, and be fed to the outside with as few elbows as possible.

Both of these factors increase efficiency and simultaneously reduce the noise level.

For range hoods typical today, the following nominal widths should be ensured for the exhaust air conduits:

Up to 600 m ³ /h	min. ø 125 mm
Over 600–1000 m ³ /h	min. ø 150 mm

When using flat channels, the conduit cross section should be increased by 15% compared to pipes. The flat channel has a higher friction coefficient and should not be used below 80 mm height or width.

Please note the following:

- As the length of the exhaust air conduit increases, the counterpressure increases and the air flow rate decreases.
- The nominal width of the exhaust air conduit must be adapted to the air flow rate of the hood.
- Reductions in the nominal width increase the counterpressure.
- Increases in the nominal width have a positive effect.
- Use small elbows (45° elbows if possible).
- Do not allow any thermal bridges to develop (condensation of water). Insulate the entire exhaust air conduit in the cold area or in unheated zones.
- For hoods with a roof outlet – particularly in the case of short pipes – a condensate trap may be necessary.
- Use non-return flap valves at the end of the air outlet.
- Use non-return flap valves in the wall box.
- Avoid the telephony effect in central pipework. Install a motor flap which can be controlled.
- Only use a non-return flap valve in an exhaust air conduit (exception: central exhaust shaft).
- Lay flexible aluminium hoses tautly.
- Horizontal exhaust air conduits must be installed with at least a 1% downhill gradient towards the outside. This will enable any condensate produced to run off.
- Do not plan the exhaust air conduit outlet to be on the side exposed to weather. The wind can significantly impair the functioning of the extraction hood or make it impossible for it to function depending on the weather conditions.



Exhaust air conduit with at least a 1 % downhill gradient towards the outside.

Types of pipe

The choice of piping depends on the following factors:

- Material: fire authority regulations
- Diameter
- Surface
- Insulation
- Suitability for installation
- ▶ Suitability for service and repair
- ▶ Suitability for cleaning
- ▶ Limiting heat loss
- ▶ Suitability given the space requirements

For the exhaust air conduit of a range hood, we recommend pipes with smooth walls which produce as little air turbulence as possible. A straight pipe layout is ideally suited for pipes with smooth walls. If the pipeline run is angled and there are elbows, flexible aluminium hoses can help to avoid sharp edges. Corrugated and spiral hoses provide the worst flow conditions and tend to generate noise as a result of buffeting.

Pipe with smooth walls

Pipe with favourable air flow properties for optimal pipework.

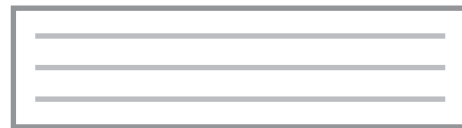

Flexible aluminium pipe

If stretched when laid, this pipe achieves good flow values. Ideally used when the pipeline run is angled.



Spiral hose

Use is only recommended in exceptional cases. Use is not advised due to the high levels of flow resistance and the tendency to produce buffeting noises.



Air flow

The air flow in an exhaust air conduit should have a low speed. This has two advantages:

- Quiet operation

The faster the speed of the air flow, the louder the noises produced in the exhaust air conduit will be.

High degree of comfort, low noise	2–4 m/s
Normal requirements, air noise audible	4–8 m/s
Minimal requirements, air noise clearly audible	8–15 m/s

- Low counterpressure in the exhaust air conduit

When the air speed is low, low counterpressures occur. The faster the speed of the air flow, the higher the counterpressure in the exhaust air conduit will be. The air flow rate of the range hood decreases accordingly.

Elbows

Design the exhaust air piping to have as few elbows and edges as possible. Corners with sharp edges must generally be avoided. Two 45° elbows are preferable to one 90° elbow. Use elbows with a large radius. The smaller the radius is, the higher the counter-pressure produced will be.

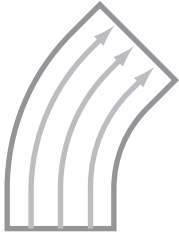

45 °elbow

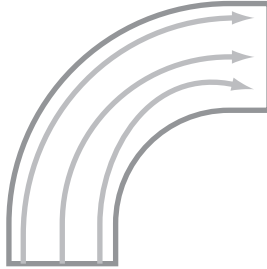

90 °elbow

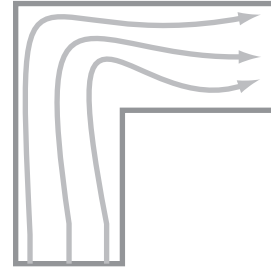

Rectangular and square runs are to be avoided.

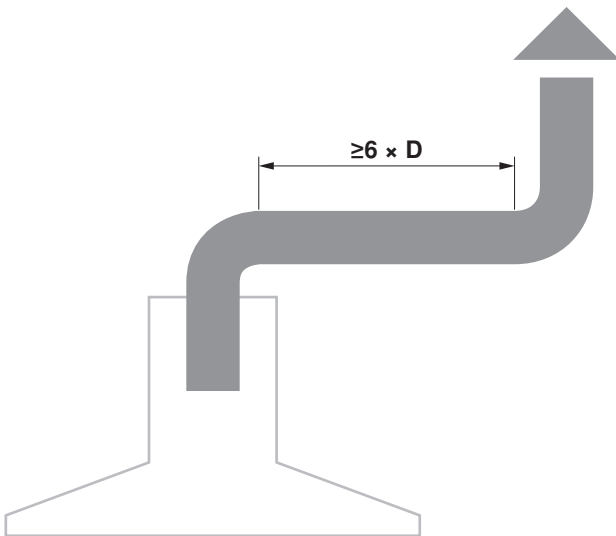

Good pipeline run

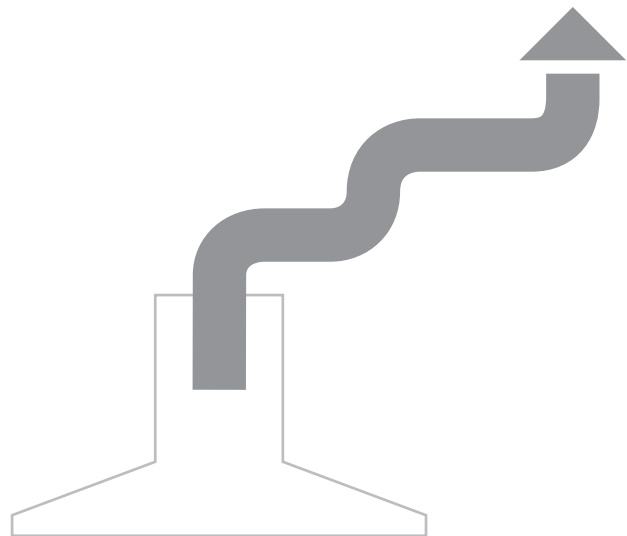

Bad pipeline run



A good pipeline layout is characterized by the fact that the distance from the first obstruction to the next (e.g. elbow) equates to at least six times the diameter of the exhaust air conduit.

Reductions/extensions

Avoid cross section reductions in the ventilation system. These produce air turbulence which generates a high counterpressure. Cross section reductions generate unnecessary noise.

Cross section extensions have a positive effect on the counterpressure. However, it should be noted here that oversizing can also have negative effects. Turbulence can cause dirt to accumulate or condensate to form.

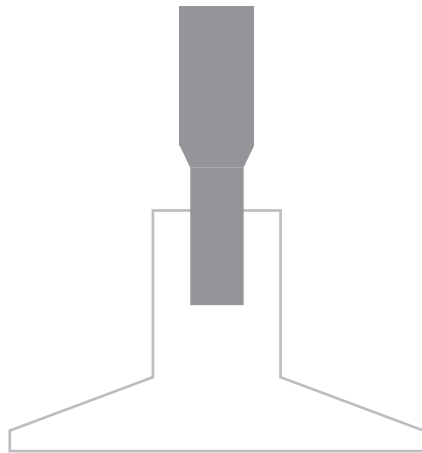

Cross section extension

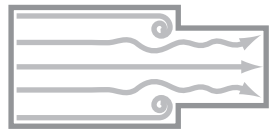

Large and angular cross section reductions increase resistance and generate turbulence.

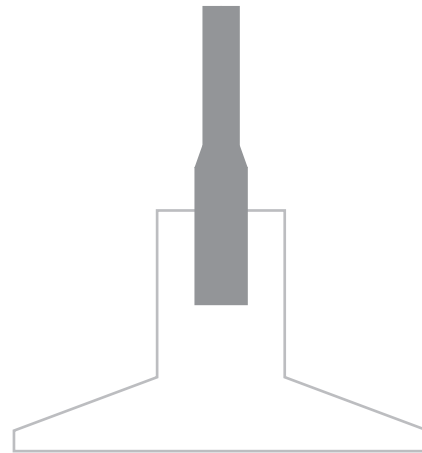

Cross section constriction



Two ducts are connected together in a section of hose. The connecting angle must not be vertical, as this would lead to the generation of turbulence and increase the air resistance. Where possible, the two ducts must be joined at an acute angle, which reduces the resistance to a minimum.

Connecting an oven to a range hood

A range hood and an oven can be connected using a y-pipe. To prevent backflow, a non-return flap valve must be installed in both appliances. The appliances and the exhaust air conduit must be planned in such a way that the appliances do not interfere with one another.

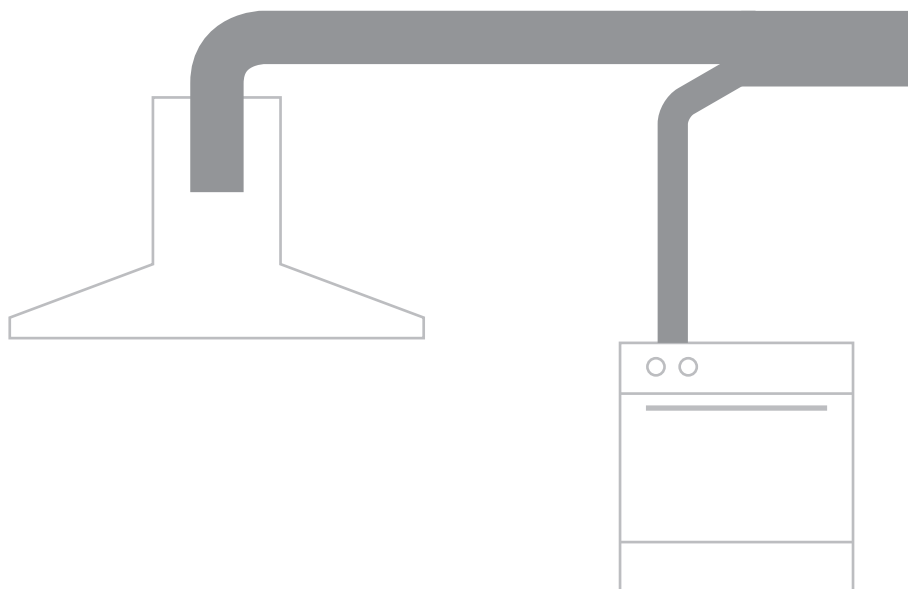

Mounting surface

A solid substrate (wall, ceiling) that does not transmit sound is the basis for establishing an acceptable level of background noise within a building. Depending on the wood construction, sound may be transmitted and/or increased.

Position of the non-return flap valve

The non-return flap valve prevents cold air from outside flowing into the exhaust air conduit and cooling the room when the range hood is switched off. In the case of a roof outlet, the extracted cooking vapours condense in the cold conduit and run back into the hood. This is why it is imperative that the non-return flap valve is fitted at the very top in the case of a roof outlet, and on the very outer edge in the case of an outlet at the side, so that no cold air is able to flow into the pipe.

There must never be several non-return flap valves installed per exhaust air conduit (exception: central shaft).

Once the non-return flap valve has been installed, its function should be tested.



Example of an exhaust air conduit

As the length (lineal metre) of the exhaust air conduit increases, the counterpressure increases and the air flow rate decreases.

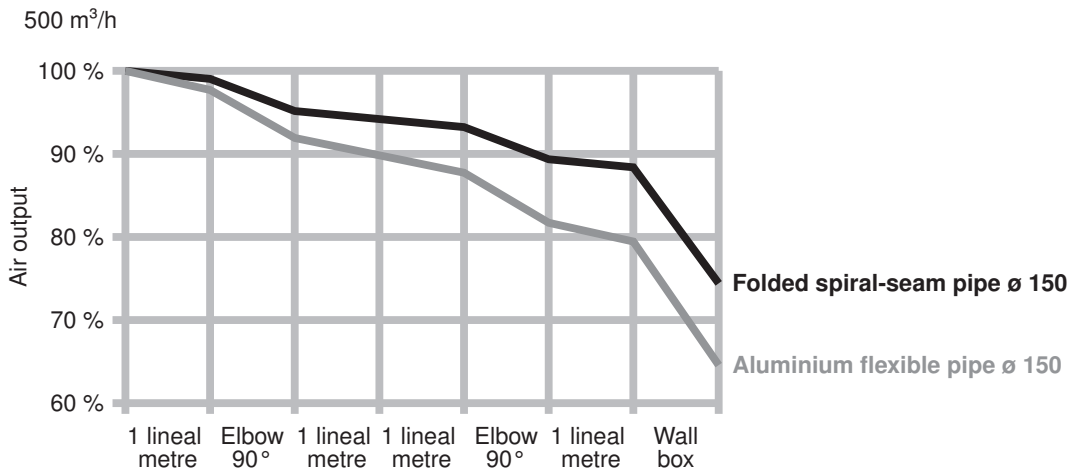

8.5 Calculation and layout of extraction hoods

Various factors must be taken into account for calculating the kitchen ventilation. A range hood has a certain air flow rate, which is expressed in cubic metres per hour. This theoretical maximum volume flow rate is reduced to an effective power by the components of the exhaust air conduit. Each metre of pipe and each elbow generates flow resistance which the fan must overcome. Note: The larger the diameter of the pipe, the less counterpressure will be produced in the exhaust air conduit. The minimum diameter of the exhaust air conduit should not be below NW 125 (NW = nominal width, corresponds to the internal diameter of the exhaust air conduit). NW 150 has become accepted as the standard for powerful appliances.

When calculating kitchen ventilation, if the minimum required air flow rate cannot be achieved on the second highest power level, then more favourable air ducting must be sought. Larger nominal widths, a shorter exhaust air conduit or fewer elbows must be planned.

You will find information about the entire range of V-ZUG kitchen appliances in the planning aid for kitchen appliances. In particular, you will find all the key dimensions and technical specifications required for comprehensive planning.

Air flow rate

The minimum required air flow rate depends on the size of the kitchen. The hoods used should be dimensioned in such a way that the air in the room is circulated or renewed 6 to 10 times per hour on the second highest power level.

The active room volume is decisive for the calculation. The room volume is calculated by multiplying the floor space of the kitchen by the room height. To obtain the active room volume, a further 20% must be deducted for the volume of the cabinets.

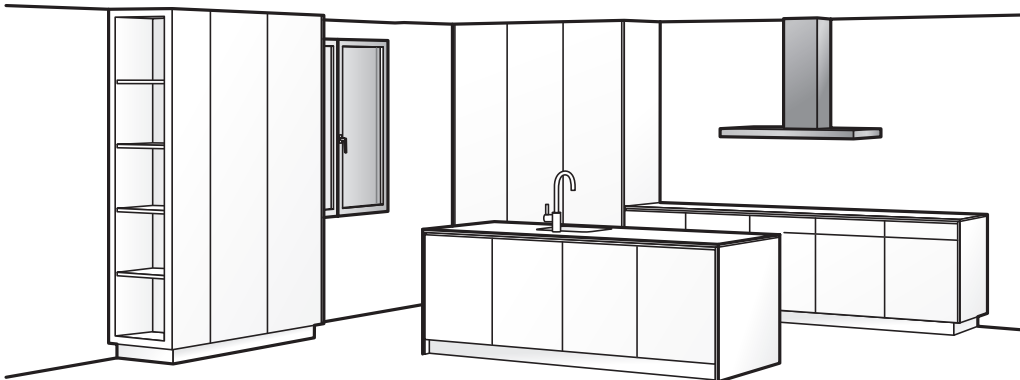

Calculation example

Active room volume:

Room volume	= floor space [m ²] × room height [m]	= 20 × 2.4 = 48 m ³
Active room volume	= room volume [m ³] – 20% (kitchen furniture volume) [m ³]	= 48 – 9.6 = 38.4 m ³

Minimum required air flow rate:

Air renewal per hour = 6 times/h

Minimum required air flow rate = 6 [times/h] × active room volume [m³] = 6 × 38.4 = 230.4 m³/h



p-V diagram

Each range hood has a unique air flow rate. This is best illustrated in a p-V diagram which plots the air flow rate for all power levels of the fan in relation to the counterpressure.

Example:

- The p-V diagram shows that at level 4 and with 0 pascals of counterpressure, the theoretical volume flow rate is 825 m³/h. In practice, this would mean that no piping is connected to the range hood and no counterpressure can therefore be produced.
- At level 4 with 425 pascals of counterpressure, the volume flow rate would be 0 m³/h. In practice, this would mean that the piping to the range hood is closed and no air is being conveyed. 425 pascals is therefore the maximum pressure the range hood is able to produce without conveying air.

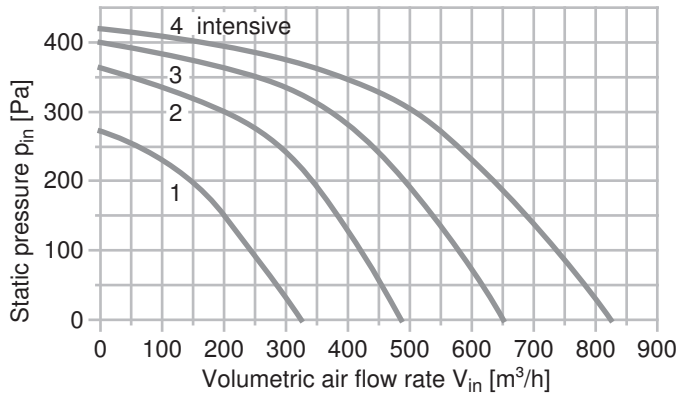

The air flow rate at each individual level is illustrated in relation to the static pressure.



At V-ZUG, the air flow rates are specified in accordance with the European standard IEC 61591. This standard contains an operating situation under defined conditions, so it is practical. The often specified "free blowing" value is not helpful for the end user as this operating situation does not occur in practice.

Taking the system characteristic curve into consideration

In addition to considering the volume flow and the volume flow rate, what is known as the system characteristic curve must also be taken into account. The system characteristic curve results from combining the static counterpressure and the volume flow rate. Each exhaust air conduit has a unique static counterpressure, which is built up from the pipe resistance.

Pipe - NW	Air flow rate in pipe m ³ /h	Air velocity in pipe m/sec	Specific resistance values in Pa							
			Sheet metal pipe, rigid Pa/m	Aluminium pipe, flexible Pa/m	Elbow, rigid 90° Pa	Elbow, flexible 90° Pa	Telescopic wall pipe Pa	Weather protection-grille Pa	Reduction 125/100 150/125 Pa	Non-return flap valve Pa
125	200	4.5	2.0	3.0	6.0	8.0	40	6.0	24	20
	250	5.7	3.0	4.0	10	13	50	10	37	22
	300	6.8	5.0	6.0	14	18	67	14	53	25
	400	9.1	8.0	10	26	34	122	24	98	30
	500	11.3	13	17	40	52	180	37	148	44
	600	13.9	17	23	61	80	260	55	218	55
	700	16.3	21	30	82	105	-	78	-	68
150	200	3.1	0.9	1.1	3.0	4.0	27	4.0	7.0	13
	300	4.7	1.8	2.4	7.0	10	55	7.0	17	18
	400	6.3	3.3	4.3	12	16	84	13	30	20
	500	7.8	5.0	6.5	19	25	117	20	45	24
	600	9.4	7.0	9.1	28	37	175	28	66	30
	700	10.8	9.0	12	38	50	240	37	88	35
	800	12.4	11	16	48	63	-	47	118	47

10 Pa (Pascal) correspond to ~ 1 mm WC (water column)
Source reference: Swiss Kitchen Association (KVS), Technical guide on kitchen planning and design, 02/2020 edition



Example system characteristic curve

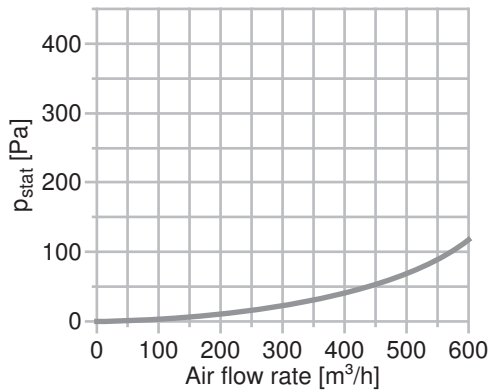

The better the on-site ventilation system is, the flatter and therefore better the system characteristic curve will be. This means that an optimal result can be achieved at low levels and with a low noise level.

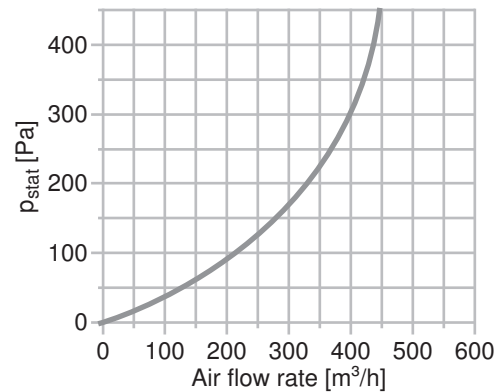

With a steep system characteristic curve, a powerful range hood is recommended as it has to overcome more counter-pressure. However, it must operate at a higher level, which results in a higher noise level.

Interpreting an air flow diagram

The junction of the system characteristic curve and the p-V characteristic curve for different range hoods identifies which range hood is most suitable. The p-V characteristic curves of a range hood and a system characteristic curve are illustrated in the air flow diagram below.

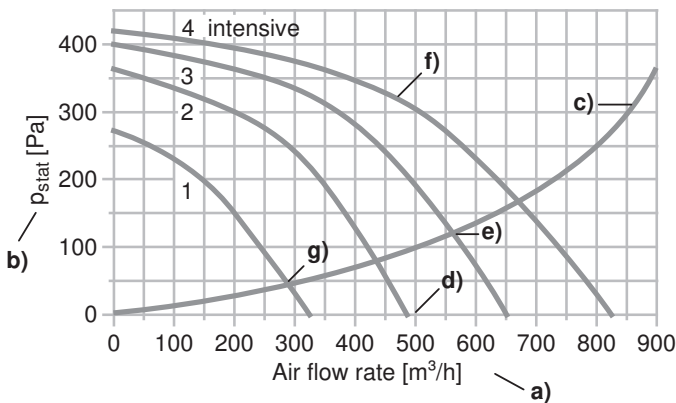

- a) Air flow rate in m³/h
- b) Static pressure in Pa (dependent on on-site counterpressure)
- c) System characteristic curve after taking into consideration the on-site factors
- d) Calculated volume flow (500 m³/h), free blowing
- e) Working point of the system at level 3. At this point, with a static counterpressure of 120 Pa, a maximum of 560 m³/h is conveyed.
- f) p-V characteristic curve of a range hood (determined in accordance with IEC 61591) for level 4.
- g) Working point of the system at level 1.

Calculation example

The minimum air flow rate of 230.4 m³/h was calculated for an active room volume of 38.4 m³. This air flow rate can be achieved at working point e) and even g) at the lowest level.



9 Care and maintenance

9.1 Handling filters

Cleaning intervals

- Metal grease filters
 - The metal grease filter should be cleaned upright and on its own in a dishwasher or in hot washing-up water every 2 weeks. The surface of the filter may darken in colour as a result. The discolouration does not signify a deterioration in function and does not constitute cause for complaint. The filter should be cleaned on its own in a dishwasher, as it may otherwise be affected by ionic discharge (sacrificial anode).
- Metal grease filters and combi grease filters
 - With normal use, the metal grease filters and the combi grease filters must be cleaned upright and on their own in a dishwasher or in hot washing-up water at least once a month. The surface of the metal grease filters may darken in colour as a result. The discolouration does not signify a deterioration in function and does not constitute cause for complaint.
 - In the case of stubborn soiling: Spray with a grease-dissolving spray, allow to react, rinse off well and then clean in the dishwasher.

Changing the standard activated charcoal filters

This is very much dependent on use and the type of cooking vapours. Depending on the quantity of activated charcoal, the average service life of an activated charcoal filter is between 3 months and 5 years. The filter can be disposed of with normal household waste.

Long-life activated charcoal filters

This filter can be used several times. It can be cleaned and reactivated in the oven. The average service life is 3 years. The filter can be disposed of with normal household waste.

Cleaning

- In a dishwasher at 65 °C (intensive programme). The filter must be washed on its own to prevent soiling by food residue.
- Or
- Immerse in 60°C water and regular detergent in the kitchen sink for an hour. Rinse well afterwards with clean water.

Reactivation

- Dry in an oven for 60 minutes at 100 °C with top/bottom heat. Place the filter on the wire shelf.
- Or
- Dry in an oven for 60 minutes at 100° C with hot air. Place the filter on the wire shelf.

Long-life-Plus activated charcoal filters

The long-life-Plus activated charcoal filter can be used again and again. It can be reactivated in the oven every 3 to 6 months. The average service life is approx. 3 years. The filter can be disposed of at a suitable recycling point.

Reactivation

- Regenerate in an oven for 60 minutes at 200° C with top/bottom heat or hot air. Place the filter on the wire shelf.



10 Troubleshooting

10.1 What to do if...

... the appliance will not switch on

Possible cause	Solution
<ul style="list-style-type: none"> No mains voltage 	<ul style="list-style-type: none"> ▶ Check the fuse and the mains cable ▶ Check whether the plug is inserted into the mains socket
<ul style="list-style-type: none"> Flat panel hood is not pulled out 	<ul style="list-style-type: none"> ▶ Pull out the flat panel and put into operation
<ul style="list-style-type: none"> Not known 	<ul style="list-style-type: none"> ▶ Disconnect the appliance from the power supply

... condensate forms on the appliance or the extraction power is insufficient

Possible cause	Solution
<ul style="list-style-type: none"> The cross section of the exhaust air conduit is too small 	<ul style="list-style-type: none"> ▶ Increase the cross section ▶ Use a pipe with smooth walls
<ul style="list-style-type: none"> Exhaust air conduit with obstruction 	<ul style="list-style-type: none"> ▶ Remove obstruction
<ul style="list-style-type: none"> Exhaust air conduit has been poorly laid 	<ul style="list-style-type: none"> ▶ Improve the way in which the exhaust air conduit is laid
<ul style="list-style-type: none"> Non-return flap valve is jammed 	<ul style="list-style-type: none"> ▶ Do not fasten the hose clamp around the non-return flap valve ▶ Use a metal ring
<ul style="list-style-type: none"> Several non-return flap valves have been installed 	<ul style="list-style-type: none"> ▶ There should only be one non-return flap valve
<ul style="list-style-type: none"> Water was boiled without the appliance having been switched on 	<ul style="list-style-type: none"> ▶ Switch the appliance on 5 minutes before starting to cook ▶ Install the appliance higher
<ul style="list-style-type: none"> The negative pressure in the room is too high 	<ul style="list-style-type: none"> ▶ Enable supply of replacement air

... the appliance drips in left-on mode

Possible cause	Solution
<ul style="list-style-type: none"> No after-running time after cooking 	<ul style="list-style-type: none"> ▶ Leave the appliance running at a low level after cooking
<ul style="list-style-type: none"> If a roof outlet is used, the non-return flap valve is directly next to the hood 	<ul style="list-style-type: none"> ▶ Install the non-return flap valve at the end of the exhaust air conduit ▶ Install a condensate tank

... condensate forms on the walls

Possible cause	Solution
<ul style="list-style-type: none"> Water was boiled without the appliance having been switched on 	<ul style="list-style-type: none"> ▶ Switch the appliance on 5 minutes before starting to cook
<ul style="list-style-type: none"> Operation at too high a level 	<ul style="list-style-type: none"> ▶ Select a lower level

... droplets of grease form, the appliance is heavily soiled, or grease and deposits can be seen on furniture

Possible cause	Solution
<ul style="list-style-type: none"> The appliance was switched on too late 	<ul style="list-style-type: none"> ▶ Switch the appliance on 5 minutes before starting to cook
<ul style="list-style-type: none"> The negative pressure in the room is too high 	<ul style="list-style-type: none"> ▶ Enable supply of replacement air
<ul style="list-style-type: none"> Operation with extraction power at too low a level 	<ul style="list-style-type: none"> ▶ Select a higher level



... the air quality deteriorates

Possible cause	Solution
• Saturated grease filter	▶ Clean or replace
• Saturated activated charcoal filter	▶ Replace
• Conduit cross section too small	▶ Enlarge the cross section
• Duct bundle too small	▶ Enlarge the duct bundle
• Flat channel too small	▶ Enlarge the flat channel
• Flexible aluminium hose kinked or not stretched	▶ Stretch and smooth out the hose ▶ Use pipes with smooth walls
• Exhaust air conduit too long	▶ Structural modification, shorten the conduit ▶ Increase power ▶ Switch to recirculation mode
• Too many elbows in the conduit	▶ Lay the pipe to have a direct route
• Elbows too narrow	▶ Use larger elbows
• Insufficient room ventilation	▶ Ensure supply of replacement air
• Exhaust air conduit blocked	▶ Check the non-return flap valve ▶ Check the wall box ▶ Check the filter ▶ Check the duct bundle

... the extraction power in recirculation mode is insufficient

Possible cause	Solution
• Charcoal in the activated charcoal filter is saturated	▶ Replace the activated charcoal filter

... odours can still be detected in the kitchen

Possible cause	Solution
• Appliance switched on too late – not run for an extra amount of time	▶ Leave the appliance running five minutes before and after cooking ▶ Carry out purge ventilation

... the negative pressure in the room is high

Possible cause	Solution
• Airtight doors and windows	▶ Open windows (more than 2 m away, preferably on the opposite side of the room)

... smoke develops while the chimney is in use

Possible cause	Solution
• Negative pressure due to the appliance	▶ Install separate replacement air units ▶ Do not use a firing system which is dependent on air and the appliance together ▶ Install a window contact switch



Notes

CONTACT IN SWITZERLAND

V-ZUG Ltd
Industriestrasse 66
6302 Zug/Switzerland
www.vzug.com

Service & Support International
service-support@vzug.com

